



SUBMITTAL DATA - OUTDOOR UNIT
VEP192C432Y
VRF HEAT PUMP
208-230/3/60

Job Name: _____
Location: _____
Schedule No.: _____
System Designation: _____

Engineer: _____
Architect: _____
Date: _____
For: ___ Reference ___ Approval ___ Review ___ Construction

FEATURES

- Two-pipe heat pump
- Accelerated complete coil defrost
- ECM Motors
- Thermal and Current Protection
- Access to electrical box for ease of maintenance
- Compressor mounted on vibration isolation pads
- Intelligent duty cycle operation
- Two stages oil separation
- Electronic Expansion Valves
- Brazed Connections
- Subcooling Control Technology
- Automatic Oil Balance

PRODUCT WARRANTY

Compressor - Seven year limited warranty
 All other components - Five year limited warranty

SPECIFICATIONS

PERFORMANCE

Cooling Capacity* (Btu/h)		184,000	
EER	(W/W)	Ducted	3.11
		Non Ducted	3.31
		Mixed	N/A
	(Btu/h)/W	Ducted	10.60
		Non Ducted	11.30
		Mixed	N/A
IEER	(Btu/h)/W	Ducted	21.30
		Non Ducted	23.00
		Mixed	N/A
Cooling Power Input (W)		7,300 + 7,300	
Heating Capacity(47°F)* (Btu/h)		206,000	
COP (47°F)	(W/W)	Ducted	3.25
		Non Ducted	3.40
		Mixed	N/A
Heating Capacity (17°F)* (Btu/h)		134,000	
COP (17°F)	(W/W)	Ducted	2.26
		Non Ducted	2.10
		Mixed	N/A
Heating Power Input (W)		7,850 + 7,850	

ELECTRICAL DATA

Power Supply (V/PH/Hz)	208-230/3/60
MOCP (A)	45 + 45
MCA (A)	37 + 37
Circuit Breaker Capacity (A)	45 + 45

GENERAL DATA

Combination Ratio Indoor / Outdoor	50% to 135%
Max. # of Indoor Units	32
Sound Pressure Level (dBA)	64
Refrigerant Type	R410a
Factory Refrigerant Charge (oz)	398.7 + 398.7
Compressor Type/Qty	Inverter Scroll / 1 + 1
Fan Type/Qty	Axial / 2 + 2

DIMENSIONS

Unit Dimensions (in)	Height	63 1/4 + 63 1/4
	Width	52 3/4 + 52 3/4
	Depth	30 1/8 + 30 1/8
Liquid Pipe Connection (in)	3/8 + 3/8	
Gas Pipe Connection (in)	7/8 + 7/8	
Oil Pipe Connection (in)	3/8 + 3/8	
Shipping Weight (lb)	695 + 695	
Net Weight (lb)	662 + 662	



NOTES:
 *Cooling and Heating Capacity data AHRI-1230-2010 conditions



NOTE – Due to Lennox' ongoing commitment to quality, Specifications, Ratings and Dimensions subject to change without notice and without incurring liability. Improper installation, adjustment, alteration, service or maintenance can cause property damage or personal injury. Installation and service must be performed by a qualified installer and servicing agency. ©2019 Lennox Industries Inc.



SUBMITTAL DATA - OUTDOOR UNIT
VEP192C432Y
VRF HEAT PUMP
208-230/3/60

DIMENSIONAL DRAWINGS

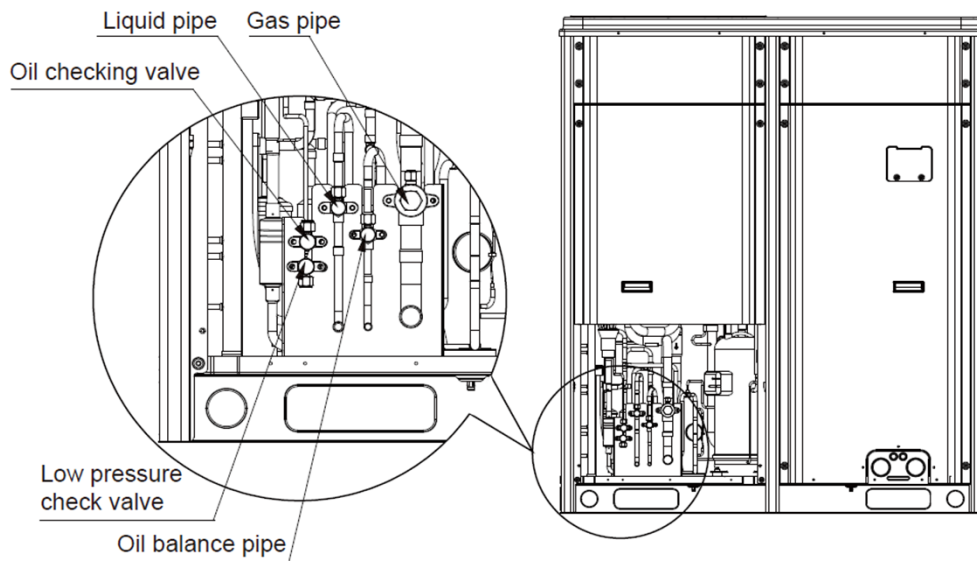
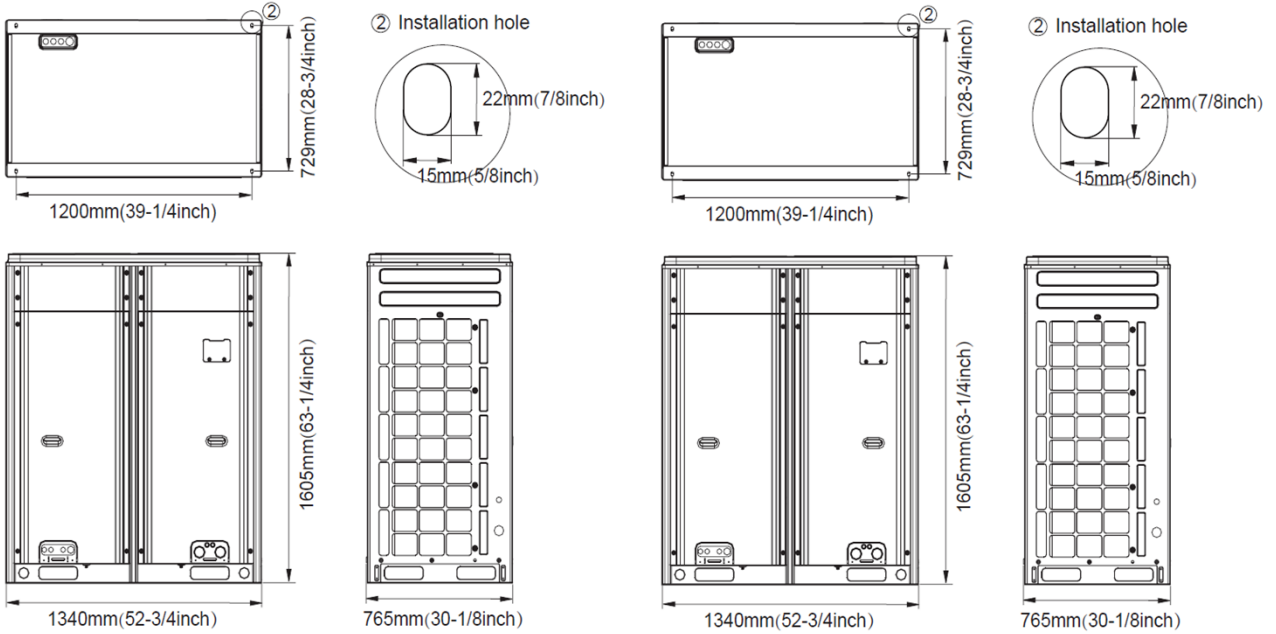

NOTE – Due to Lennox' ongoing commitment to quality, Specifications, Ratings and Dimensions subject to change without notice and without incurring liability. Improper installation, adjustment, alteration, service or maintenance can cause property damage or personal injury. Installation and service must be performed by a qualified installer and servicing agency. ©2019 Lennox Industries Inc.