



**SUBMITTAL DATA - INDOOR UNIT**  
**VE1C007N432U**  
**VRF 1-WAY CASSETTE TYPE EVAPORATOR**

**Job Name:** \_\_\_\_\_  
**Location:** \_\_\_\_\_  
**Schedule No.:** \_\_\_\_\_  
**System Designation:** \_\_\_\_\_

**Engineer:** \_\_\_\_\_  
**Architect:** \_\_\_\_\_  
**Date:** \_\_\_\_\_  
**For:** \_\_\_ Reference \_\_\_ Approval \_\_\_ Review \_\_\_ Construction

**FEATURES**

- Auto Addressing installation
- Auto Restart
- Integrated Condensate Pump
- Built-in Electronic Expansion Valve
- LED Display
- Washable Filter
- Anti-Freezing Protection

**PRODUCT WARRANTY**

All covered components - one year limited warranty

**SPECIFICATIONS**

**PERFORMANCE**

Cooling Capacity* (Btu/h)		7,506
Heating Capacity* (Btu/h)		8,530
Airflow (CFM)	High	355
	Medium	295
	Low	265

Sound Pressure Level (dBA)                      H / M / L    36/32/28

**ELECTRICAL DATA**

Power Supply (V / Hz / Ph)	220-240/50/1 - 208-230/60/1
MOP (A)	6
Rated Current (A)	Cooling    0.2
	Heating    0.2

**DIMENSIONS**

Unit Dimensions (in)	Height	7
	Width	39
	Depth	15 1/4

Liquid Pipe Connection (in)	1/4
Gas Pipe Connection (in)	3/8
Shipping Weight (lb)	13.2
Net Weight (lb)	9.3

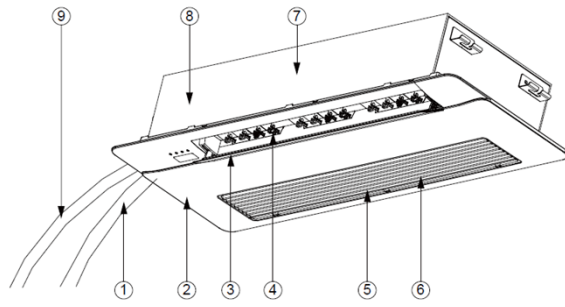

1. Pipe Connection
2. Front Panel
3. Air Louver
4. Swing Louvers
5. Air Grill
6. Air Filter
7. Main Body
8. Built-in Condensate Pump
9. Drain Pipe

**NOTES:**

\*Cooling and Heating Capacity data is rated at the following conditions:

Cooling: 80 °F DB / 67 °F WB Indoor, 95 °F DB Outdoor

Heating: 70 °F DB Indoor, 47 °F DB

NOTE – Due to Lennox' ongoing commitment to quality, Specifications, Ratings and Dimensions subject to change without notice and without incurring liability. Improper installation, adjustment, alteration, service or maintenance can cause property damage or personal injury. Installation and service must be performed by a qualified installer and servicing agency. ©2015 Lennox Industries Inc.



**SUBMITTAL DATA - INDOOR UNIT**  
**VE1C007N432U**  
**VRF 1-WAY CASSETTE TYPE EVAPORATOR**

**DIMENSIONAL DRAWINGS**

**TOP VIEW**

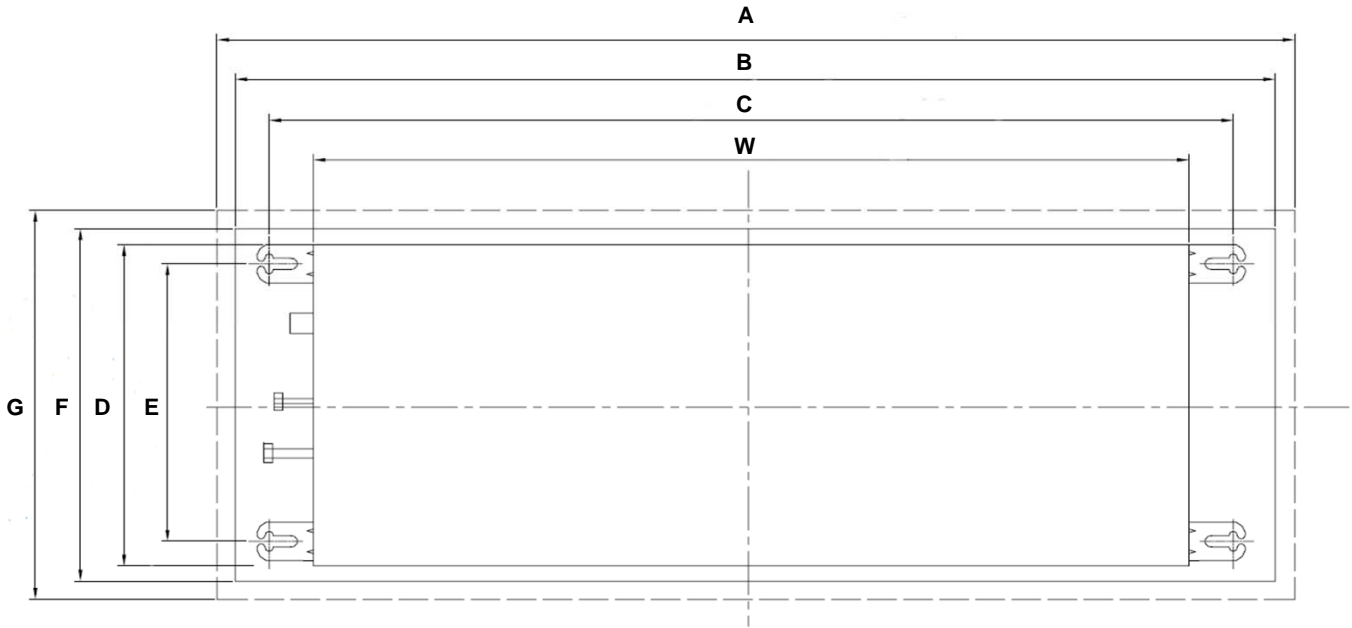

Side	mm	in	Description
A	1200	47 1/4	Front Panel Width
B	1115	44	Ceiling Outlet Width
C	1027	40 1/2	Holding Brackets Width
W	987	39	Width
E	261	10 1/4	Holding Brackets Depth
D	385	15 1/4	Depth
F	415	16 1/4	Ceiling Outlet Depth
G	456	18	Front Panel Depth

NOTE – Due to Lennox' ongoing commitment to quality, Specifications, Ratings and Dimensions subject to change without notice and without incurring liability. Improper installation, adjustment, alteration, service or maintenance can cause property damage or personal injury. Installation and service must be performed by a qualified installer and servicing agency. ©2015 Lennox Industries Inc.



**SUBMITTAL DATA - INDOOR UNIT**  
**VE1C009N432U**  
**VRF 1-WAY CASSETTE TYPE EVAPORATOR**

**Job Name:** \_\_\_\_\_  
**Location:** \_\_\_\_\_  
**Schedule No.:** \_\_\_\_\_  
**System Designation:** \_\_\_\_\_

**Engineer:** \_\_\_\_\_  
**Architect:** \_\_\_\_\_  
**Date:** \_\_\_\_\_  
**For:** \_\_\_ Reference \_\_\_ Approval \_\_\_ Review \_\_\_ Construction

**FEATURES**

- Auto Addressing installation
- Auto Restart
- Integrated Condensate Pump
- Built-in Electronic Expansion Valve
- LED Display
- Washable Filter
- Anti-Freezing Protection

**PRODUCT WARRANTY**

All covered components - one year limited warranty

**SPECIFICATIONS**

**PERFORMANCE**

Cooling Capacity* (Btu/h)		9,554
Heating Capacity* (Btu/h)		10,918
Airflow (CFM)	High	355
	Medium	295
	Low	265

Sound Pressure Level (dBA)                      H / M / L    36/32/28

**ELECTRICAL DATA**

Power Supply (V / Hz / Ph)	220-240/50/1 - 208-230/60/1
MOP (A)	6
Rated Current (A)	Cooling    0.2
	Heating    0.2

**DIMENSIONS**

Unit Dimensions (in)	Height	7
	Width	39
	Depth	15 1/4

Liquid Pipe Connection (in)	1/4
Gas Pipe Connection (in)	3/8
Shipping Weight (lb)	13.2
Net Weight (lb)	9.3

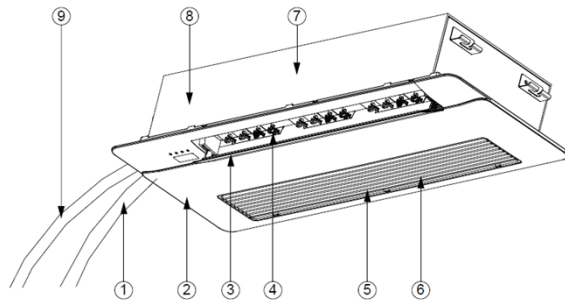

1. Pipe Connection
2. Front Panel
3. Air Louver
4. Swing Louvers
5. Air Grill
6. Air Filter
7. Main Body
8. Built-in Condensate Pump
9. Drain Pipe

**NOTES:**

\*Cooling and Heating Capacity data is rated at the following conditions:

Cooling: 80 °F DB / 67 °F WB Indoor, 95 °F DB Outdoor

Heating: 70 °F DB Indoor, 47 °F DB

NOTE – Due to Lennox' ongoing commitment to quality, Specifications, Ratings and Dimensions subject to change without notice and without incurring liability. Improper installation, adjustment, alteration, service or maintenance can cause property damage or personal injury. Installation and service must be performed by a qualified installer and servicing agency. ©2015 Lennox Industries Inc.



**SUBMITTAL DATA - INDOOR UNIT**  
**VE1C009N432U**  
**VRF 1-WAY CASSETTE TYPE EVAPORATOR**

**DIMENSIONAL DRAWINGS**

**TOP VIEW**

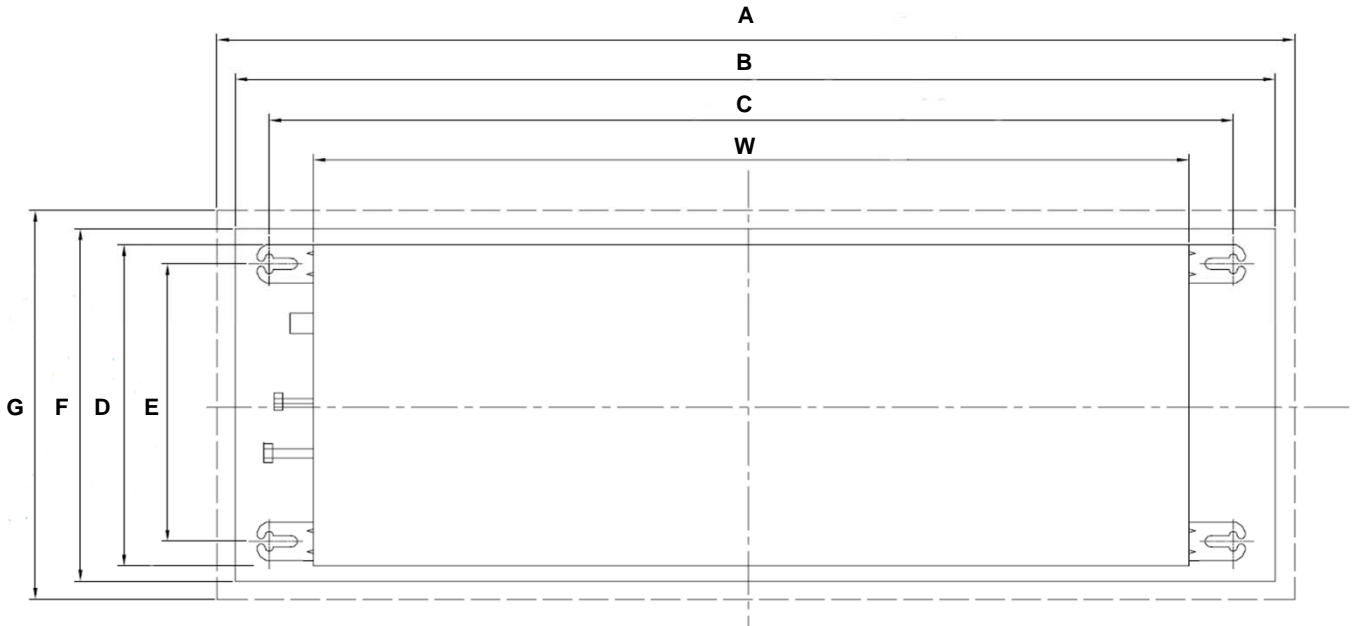

Side	mm	in	Description
A	1200	47 1/4	Front Panel Width
B	1115	44	Ceiling Outlet Width
C	1027	40 1/2	Holding Brackets Width
W	987	39	Width
E	261	10 1/4	Holding Brackets Depth
D	385	15 1/4	Depth
F	415	16 1/4	Ceiling Outlet Depth
G	456	18	Front Panel Depth

NOTE – Due to Lennox' ongoing commitment to quality, Specifications, Ratings and Dimensions subject to change without notice and without incurring liability. Improper installation, adjustment, alteration, service or maintenance can cause property damage or personal injury. Installation and service must be performed by a qualified installer and servicing agency. ©2015 Lennox Industries Inc.



**SUBMITTAL DATA - INDOOR UNIT**  
**VE1C012N432U**  
**VRF 1-WAY CASSETTE TYPE EVAPORATOR**

**Job Name:** \_\_\_\_\_  
**Location:** \_\_\_\_\_  
**Schedule No.:** \_\_\_\_\_  
**System Designation:** \_\_\_\_\_

**Engineer:** \_\_\_\_\_  
**Architect:** \_\_\_\_\_  
**Date:** \_\_\_\_\_  
**For:** \_\_\_ Reference \_\_\_ Approval \_\_\_ Review \_\_\_ Construction

**FEATURES**

- Auto Addressing installation
- Auto Restart
- Integrated Condensate Pump
- Built-in Electronic Expansion Valve
- LED Display
- Washable Filter
- Anti-Freezing Protection

**PRODUCT WARRANTY**

All covered components - one year limited warranty

**SPECIFICATIONS**

**PERFORMANCE**

Cooling Capacity* (Btu/h)		12,283
Heating Capacity* (Btu/h)		13,648
Airflow (CFM)	High	355
	Medium	295
	Low	265

Sound Pressure Level (dBA)                      H / M / L    36/32/28

**ELECTRICAL DATA**

Power Supply (V / Hz / Ph)	220-240/50/1 - 208-230/60/1
MOP (A)	6
Rated Current (A)	Cooling    0.2
	Heating    0.2

**DIMENSIONS**

Unit Dimensions (in)	Height	7
	Width	39
	Depth	15 1/4

Liquid Pipe Connection (in)	1/4
Gas Pipe Connection (in)	1/2
Shipping Weight (lb)	13.2
Net Weight (lb)	9.3

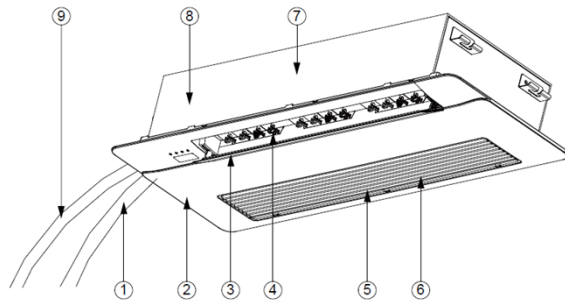

1. Pipe Connection
2. Front Panel
3. Air Louver
4. Swing Louvers
5. Air Grill
6. Air Filter
7. Main Body
8. Built-in Condensate Pump
9. Drain Pipe

**NOTES:**

\*Cooling and Heating Capacity data is rated at the following conditions:

Cooling: 80 °F DB / 67 °F WB Indoor, 95 °F DB Outdoor

Heating: 70 °F DB Indoor, 47 °F DB

NOTE – Due to Lennox' ongoing commitment to quality, Specifications, Ratings and Dimensions subject to change without notice and without incurring liability. Improper installation, adjustment, alteration, service or maintenance can cause property damage or personal injury. Installation and service must be performed by a qualified installer and servicing agency. ©2015 Lennox Industries Inc.



**SUBMITTAL DATA - INDOOR UNIT**  
**VE1C012N432U**  
**VRF 1-WAY CASSETTE TYPE EVAPORATOR**

**DIMENSIONAL DRAWINGS**

**TOP VIEW**

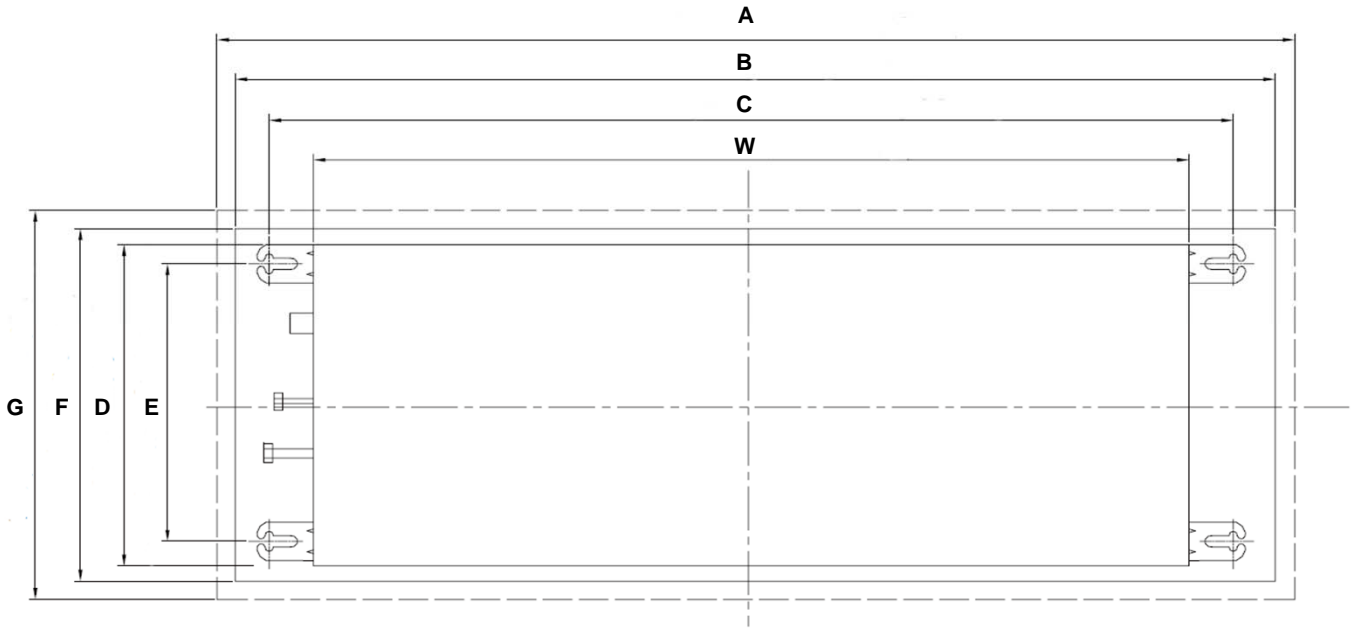

Side	mm	in	Description
A	1200	47 1/4	Front Panel Width
B	1115	44	Ceiling Outlet Width
C	1027	40 1/2	Holding Brackets Width
W	987	39	Width
E	261	10 1/4	Holding Brackets Depth
D	385	15 1/4	Depth
F	415	16 1/4	Ceiling Outlet Depth
G	456	18	Front Panel Depth

NOTE – Due to Lennox' ongoing commitment to quality, Specifications, Ratings and Dimensions subject to change without notice and without incurring liability. Improper installation, adjustment, alteration, service or maintenance can cause property damage or personal injury. Installation and service must be performed by a qualified installer and servicing agency. ©2015 Lennox Industries Inc.



**SUBMITTAL DATA - INDOOR UNIT**  
**VE1C015N432U**  
**VRF 1-WAY CASSETTE TYPE EVAPORATOR**

**Job Name:** \_\_\_\_\_  
**Location:** \_\_\_\_\_  
**Schedule No.:** \_\_\_\_\_  
**System Designation:** \_\_\_\_\_

**Engineer:** \_\_\_\_\_  
**Architect:** \_\_\_\_\_  
**Date:** \_\_\_\_\_  
**For:** \_\_\_ Reference \_\_\_ Approval \_\_\_ Review \_\_\_ Construction

**FEATURES**

- Auto Addressing installation
- Auto Restart
- Integrated Condensate Pump
- Built-in Electronic Expansion Valve
- LED Display
- Washable Filter
- Anti-Freezing Protection

**PRODUCT WARRANTY**

All covered components - one year limited warranty

**SPECIFICATIONS**

**PERFORMANCE**

Cooling Capacity* (Btu/h)		15,354
Heating Capacity* (Btu/h)		17,060
Airflow (CFM)	High	490
	Medium	355
	Low	295

Sound Pressure Level (dBA)                      H / M / L    40/35/30

**ELECTRICAL DATA**

Power Supply (V / Hz / Ph)	220-240/50/1 - 208-230/60/1
MOP (A)	6
Rated Current (A)	Cooling    0.3
	Heating    0.3

**DIMENSIONS**

Unit Dimensions (in)	Height	7
	Width	39
	Depth	15 1/4

Liquid Pipe Connection (in)	1/4
Gas Pipe Connection (in)	1/2
Shipping Weight (lb)	13.2
Net Weight (lb)	9.3

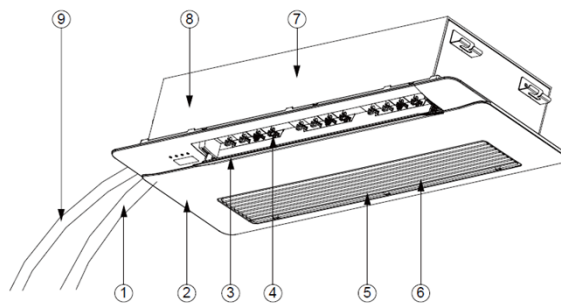

1. Pipe Connection
2. Front Panel
3. Air Louver
4. Swing Louvers
5. Air Grill
6. Air Filter
7. Main Body
8. Built-in Condensate Pump
9. Drain Pipe

**NOTES:**

\*Cooling and Heating Capacity data is rated at the following conditions:

Cooling: 80 °F DB / 67 °F WB Indoor, 95 °F DB Outdoor

Heating: 70 °F DB Indoor, 47 °F DB

NOTE – Due to Lennox' ongoing commitment to quality, Specifications, Ratings and Dimensions subject to change without notice and without incurring liability. Improper installation, adjustment, alteration, service or maintenance can cause property damage or personal injury. Installation and service must be performed by a qualified installer and servicing agency. ©2015 Lennox Industries Inc.



**SUBMITTAL DATA - INDOOR UNIT**  
**VE1C015N432U**  
**VRF 1-WAY CASSETTE TYPE EVAPORATOR**

**DIMENSIONAL DRAWINGS**

**TOP VIEW**

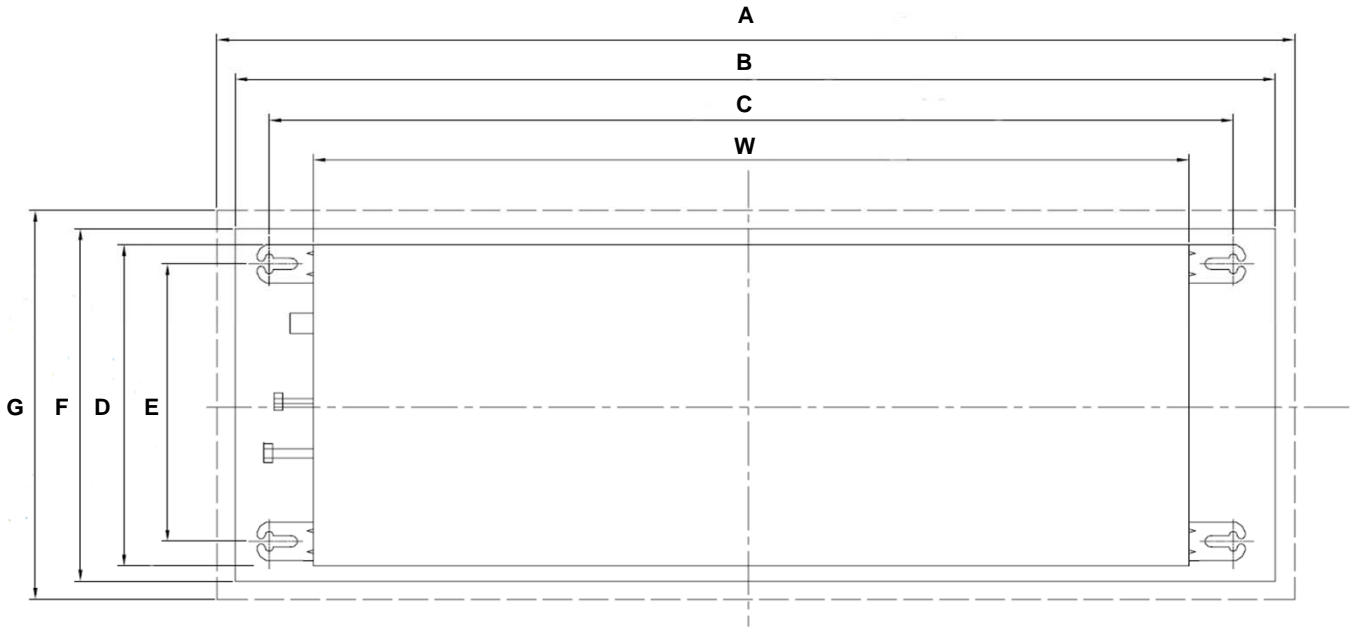

Side	mm	in	Description
A	1200	47 1/4	Front Panel Width
B	1115	44	Ceiling Outlet Width
C	1027	40 1/2	Holding Brackets Width
W	987	39	Width
E	261	10 1/4	Holding Brackets Depth
D	385	15 1/4	Depth
F	415	16 1/4	Ceiling Outlet Depth
G	456	18	Front Panel Depth

NOTE – Due to Lennox' ongoing commitment to quality, Specifications, Ratings and Dimensions subject to change without notice and without incurring liability. Improper installation, adjustment, alteration, service or maintenance can cause property damage or personal injury. Installation and service must be performed by a qualified installer and servicing agency. ©2015 Lennox Industries Inc.





**SUBMITTAL DATA - INDOOR UNIT**  
**VE1C017N432U**  
**VRF 1-WAY CASSETTE TYPE EVAPORATOR**

**Job Name:** \_\_\_\_\_  
**Location:** \_\_\_\_\_  
**Schedule No.:** \_\_\_\_\_  
**System Designation:** \_\_\_\_\_

**Engineer:** \_\_\_\_\_  
**Architect:** \_\_\_\_\_  
**Date:** \_\_\_\_\_  
**For:** \_\_\_ Reference \_\_\_ Approval \_\_\_ Review \_\_\_ Construction

**FEATURES**

- Auto Addressing installation
- Auto Restart
- Integrated Condensate Pump
- Built-in Electronic Expansion Valve
- LED Display
- Washable Filter
- Anti-Freezing Protection

**PRODUCT WARRANTY**

All covered components - one year limited warranty

**SPECIFICATIONS**

**PERFORMANCE**

Cooling Capacity* (Btu/h)		17,060
Heating Capacity* (Btu/h)		19,107
Airflow (CFM)	High	490
	Medium	355
	Low	295

Sound Pressure Level (dBA)                      H / M / L    40/35/30

**ELECTRICAL DATA**

Power Supply (V / Hz / Ph)	220-240/50/1 - 208-230/60/1
MOP (A)	6
Rated Current (A)	Cooling    0.3
	Heating    0.3

**DIMENSIONS**

Unit Dimensions (in)	Height	7
	Width	39
	Depth	15 1/4

Liquid Pipe Connection (in)	1/4
Gas Pipe Connection (in)	1/2
Shipping Weight (lb)	13.2
Net Weight (lb)	9.3

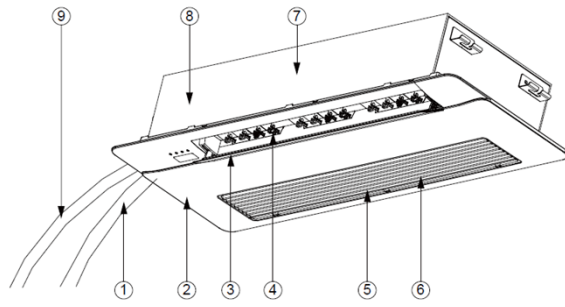

1. Pipe Connection
2. Front Panel
3. Air Louver
4. Swing Louvers
5. Air Grill
6. Air Filter
7. Main Body
8. Built-in Condensate Pump
9. Drain Pipe

**NOTES:**

\*Cooling and Heating Capacity data is rated at the following conditions:

Cooling: 80 °F DB / 67 °F WB Indoor, 95 °F DB Outdoor

Heating: 70 °F DB Indoor, 47 °F DB

NOTE – Due to Lennox' ongoing commitment to quality, Specifications, Ratings and Dimensions subject to change without notice and without incurring liability. Improper installation, adjustment, alteration, service or maintenance can cause property damage or personal injury. Installation and service must be performed by a qualified installer and servicing agency. ©2015 Lennox Industries Inc.



**SUBMITTAL DATA - INDOOR UNIT**  
**VE1C017N432U**  
**VRF 1-WAY CASSETTE TYPE EVAPORATOR**

**DIMENSIONAL DRAWINGS**

**TOP VIEW**

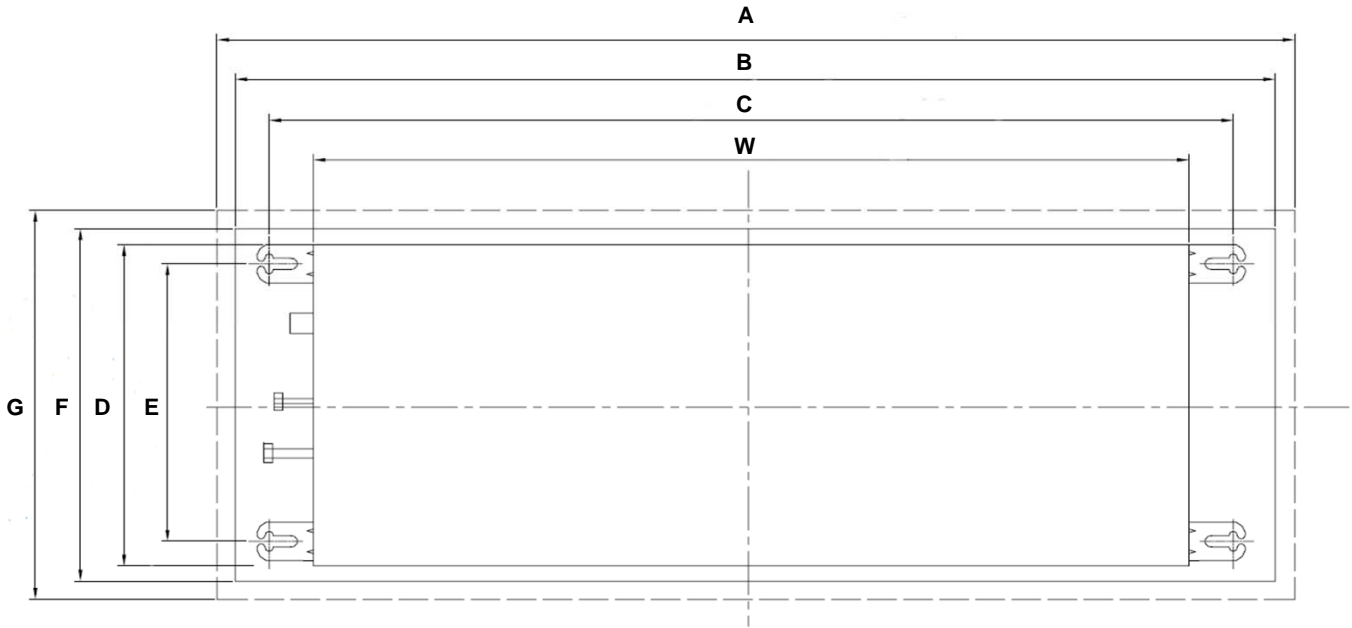

Side	mm	in	Description
A	1200	47 1/4	Front Panel Width
B	1115	44	Ceiling Outlet Width
C	1027	40 1/2	Holding Brackets Width
W	987	39	Width
E	261	10 1/4	Holding Brackets Depth
D	385	15 1/4	Depth
F	415	16 1/4	Ceiling Outlet Depth
G	456	18	Front Panel Depth

NOTE – Due to Lennox' ongoing commitment to quality, Specifications, Ratings and Dimensions subject to change without notice and without incurring liability. Improper installation, adjustment, alteration, service or maintenance can cause property damage or personal injury. Installation and service must be performed by a qualified installer and servicing agency. ©2015 Lennox Industries Inc.