



SUBMITTAL DATA - OUTDOOR UNIT
VEP072C432G
VRF HEAT PUMP
440-460/3/60

Job Name: _____
 Location: _____
 Schedule No.: _____
 System Designation: _____

Engineer: _____
 Architect: _____
 Date: _____
 For: Reference Approval Review Construction

FEATURES

- Two-pipe heat pump
- Accelerated complete coil defrost
- ECM Motors
- Thermal and Current Protection
- Access to electrical box for ease of maintenance
- Compressor mounted on vibration isolation pads
- Intelligent duty cycle operation
- Two stages oil separation
- Electronic Expansion Valves
- Brazed Connections
- Subcooling Control Technology
- Automatic Oil Balance

PRODUCT WARRANTY

Compressor - Seven year limited warranty
 All other components - Five year limited warranty

SPECIFICATIONS

PERFORMANCE

| | | | |
|---------------------------------|-----------|------------|-------|
| Cooling Capacity* (Btu/h) | | 69,000 | |
| EER | (W/W) | Ducted | 3.25 |
| | | Non Ducted | 3.31 |
| | | Mixed | 3.63 |
| | (Btu/h)/W | Ducted | 11.10 |
| | | Non Ducted | 11.30 |
| | | Mixed | 12.40 |
| IEER | (Btu/h)/W | Ducted | 20.00 |
| | | Non Ducted | 22.00 |
| | | Mixed | 23.25 |
| Cooling Power Input (W) | | 5,450 | |
| Heating Capacity(47°F)* (Btu/h) | | 77,000 | |
| COP (47°F) | (W/W) | Ducted | 3.40 |
| | | Non Ducted | 3.50 |
| | | Mixed | 3.81 |
| Heating Capacity(17°F)* (Btu/h) | | 51,000 | |
| COP (17°F) | (W/W) | Ducted | 2.40 |
| | | Non Ducted | 2.40 |
| | | Mixed | 2.46 |
| Heating Power Input (W) | | 5,800 | |

ELECTRICAL DATA

| | |
|------------------------------|--------------|
| Power Supply (V/PH/Hz) | 440-460/3/60 |
| MOCP (A) | 20 |
| MCA (A) | 15 |
| Circuit Breaker Capacity (A) | 20 |

GENERAL DATA

| | |
|------------------------------------|---------------------|
| Combination Ratio Indoor / Outdoor | 50% to 135% |
| Max. # of Indoor Units | 13 |
| Sound Pressure Level (dBA) | 60 |
| Refrigerant Type | R410a |
| Factory Refrigerant Charge (oz) | 229.3 |
| Compressor Type/Qty | Inverter Scroll / 1 |
| Fan Type/Qty | Axial / 1 |

DIMENSIONS

| | | |
|-----------------------------|--------|--------|
| Unit Dimensions (in) | Height | 63 1/4 |
| | Width | 36-5/8 |
| | Depth | 30 1/8 |
| Liquid Pipe Connection (in) | 3/8 | |
| Gas Pipe Connection (in) | 3/4 | |
| Oil Pipe Connection (in) | 3/8 | |
| Shipping Weight (lb) | 524 | |
| Net Weight (lb) | 503 | |



NOTES:
 *Cooling and Heating Capacity data AHRI-1230-2010 conditions



NOTE – Due to Lennox' ongoing commitment to quality, Specifications, Ratings and Dimensions subject to change without notice and without incurring liability. Improper installation, adjustment, alteration, service or maintenance can cause property damage or personal injury. Installation and service must be performed by a qualified installer and servicing agency. ©2019 Lennox Industries Inc.



SUBMITTAL DATA - OUTDOOR UNIT
VEP072C432G
VRF HEAT PUMP
440-460/3/60

DIMENSIONAL DRAWINGS

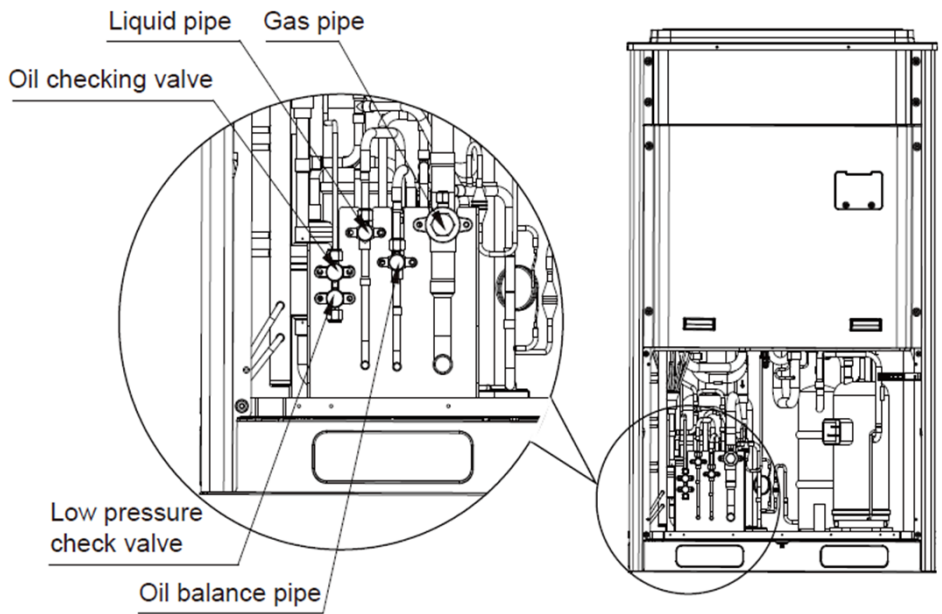
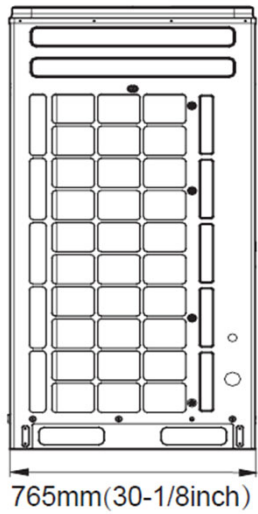
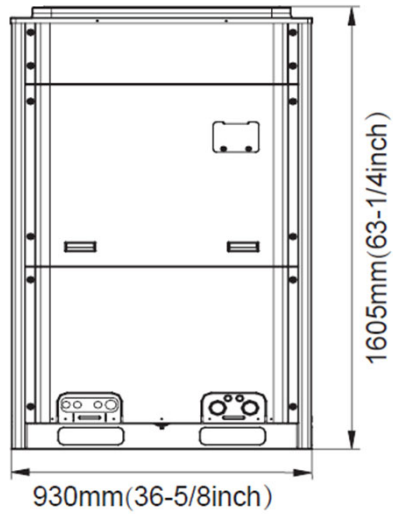
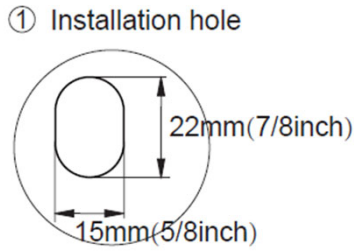
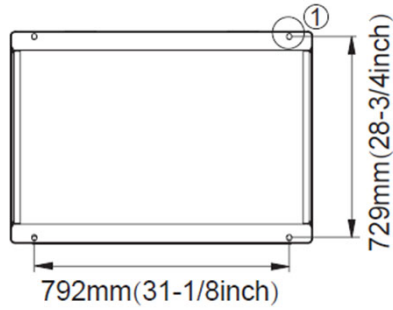

NOTE – Due to Lennox' ongoing commitment to quality, Specifications, Ratings and Dimensions subject to change without notice and without incurring liability. Improper installation, adjustment, alteration, service or maintenance can cause property damage or personal injury. Installation and service must be performed by a qualified installer and servicing agency. ©2019 Lennox Industries Inc.